



QUICK CLOSING- VALVE

567002

PN 16

No	Part	Material
1	Body	GGG40,3
2	Bonnet	GGG40,3
3	Disc	1.4021
4	Seat	1.4301
5	Stem	1.4021
6	Spring	1,4310
7	Bonnet gasket	Graphite
8	Handwheel	GG25
9	Retainer block	Brass
10	Cylinder	Brass

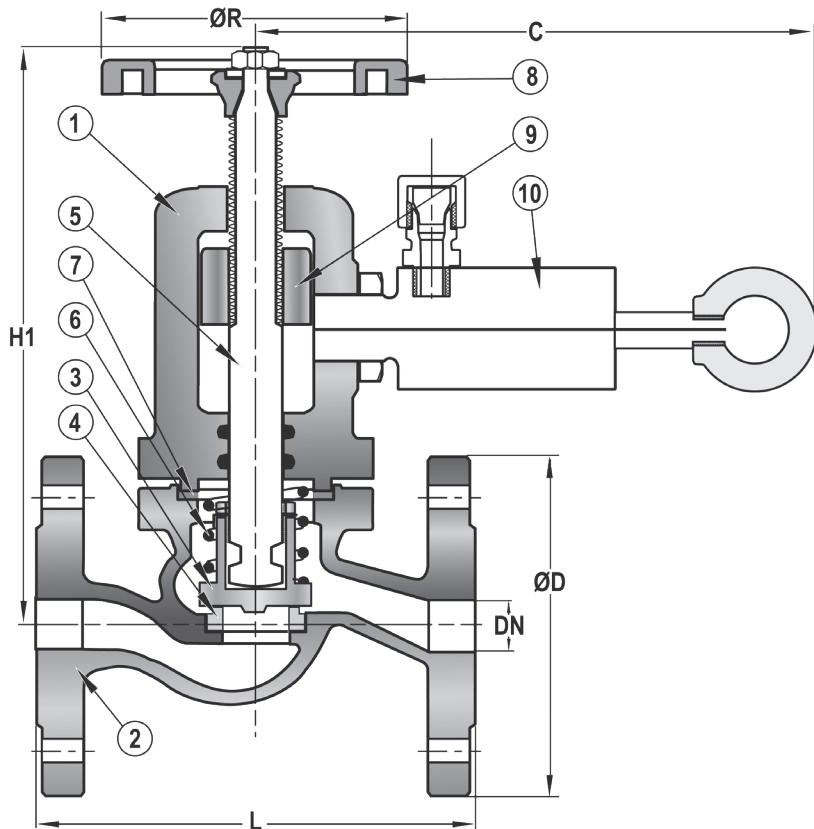

Variants:

Body and Bonnet in steel GS-C25

DN	ØD	n	Hcd	d	L	H1	RØ	C	Max working-pressure		Weight Kg
									Mpa 150 °C	Mpa	
15	95	4	65	14	130	175	120	190	1,6		6,0
20	105	4	75	14	150	175	120	190	1,6		7,0
25	115	4	85	14	160	190	140	190	1,6		8,0
32	140	4	100	18	180	190	140	190	1,6		9,0
40	150	4	110	18	200	205	160	195	1,6		13,0
50	165	4	125	18	230	215	160	195	1,6		16,0
65	185	4	145	18	290	245	180	195	1,6		21,0
80	200	8	160	18	310	270	200	195	1,6		28,0
100	220	8	180	18	350	305	225	195	1,6		40,0
125	250	8	210	18	400	330	250	195	1,6		60,0
150	285	8	240	22	480	380	300	195	1,6		110,0
200	340	8	295	22	600	450	400	195	1,0		170,0