



QUICK CLOSING- VALVE

567002
567001

PN 16
PN 10

No	Part	Material
1	Body	GGG 40.3
2	Bonnet	GGG 40.3
3	Cone	1.4021
4	Seat	1.4301
6	Stem	1.4021
8	Square nut	Steel
9	Indicator	Steel
13	Gasket	PTFE
14*	Groove ring	Viton
15	Stud bolt	Steel
16	Hex. nut	Steel
17	Spring	Spring steel
19*	Mud stripper	NBR
20	Washer	Spring steel
21	Hex. nut	Steel
22	Hand Wheel	GG-20
23	Release mechanism	Stainless steel

*Recommended spare parts

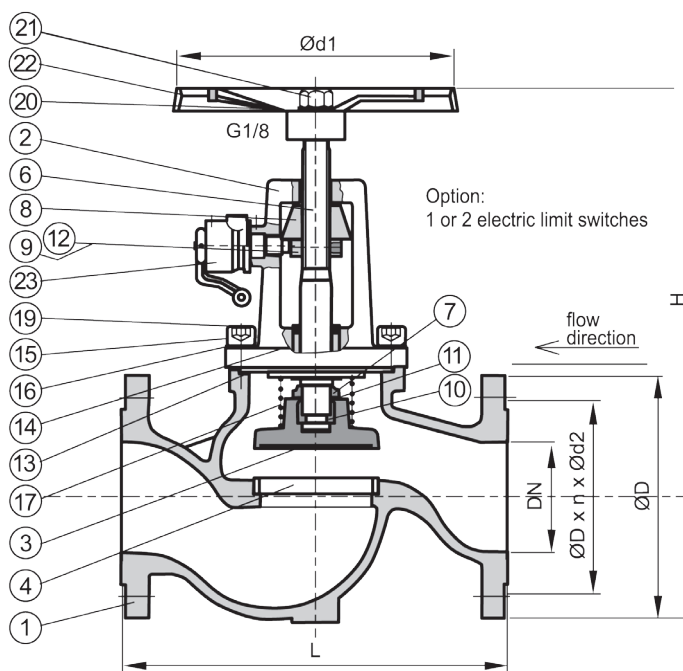

Variants: Body and Bonnet in steel GS-C25

DN	D	n	Hcd	d	L	Max working-pressure		Weight Kg
						Mpa 120 °C	Mpa 180 °C	
15	95	4	65	14	130	1,6	1,0	5,0
20	105	4	75	14	150	1,6	1,0	5,1
25	115	4	85	14	160	1,6	1,0	6,0
32	140	4	100	18	180	1,6	1,0	11,0
40	150	4	110	18	200	1,6	1,0	13,0
50	165	4	125	18	230	1,6	1,0	15,3
65	185	4	145	18	290	1,6	1,0	28,8
80	200	8	160	18	310	1,6	1,0	34,0
100	220	8	180	18	350	1,6	1,0	50,0
125	250	8	210	18	400	1,6	1,0	68,0
150	285	8	240	22	480	1,6	1,0	92,0
567001 PN10								
200	340	8	295	22	600	1,0	0,6	158,0
250	395	12	350	22	730	1,0	0,6	243,0