



CHANGE OVER VALVE

402252

PN 16

No	Part	Material
1	Body	EN-GJL-250
2	Bonnet	EN-GJL-250
1.2	Seat ring Disc	X20Cr13, 1.4021
3	Disc*	X20Cr13, 1.4021
4	Stem*	X20Cr13, 1.4021
5	Handwheel	EN-GJL-250
6	Packing ring*	Graphite
7	Hexagon screws	DN15-100: 5.6
7	Stud	DN125-250: 25CrMo4, 1.7218
8	Hexagon nut	DN125-250: C35E, 1.1181
9	Gasket*	Graphit
26	Connecting piece	DN200-250: GP240GH, 1,0619
26.2	Seat ring	DN200-250: X20Cr13, 1.4021
29	Seat ring	DN15-150: X20Cr13, 1.4021

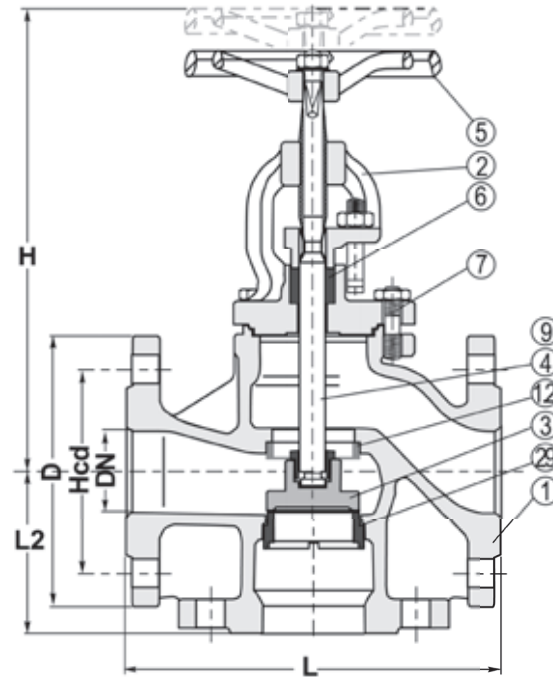

DN 150-150

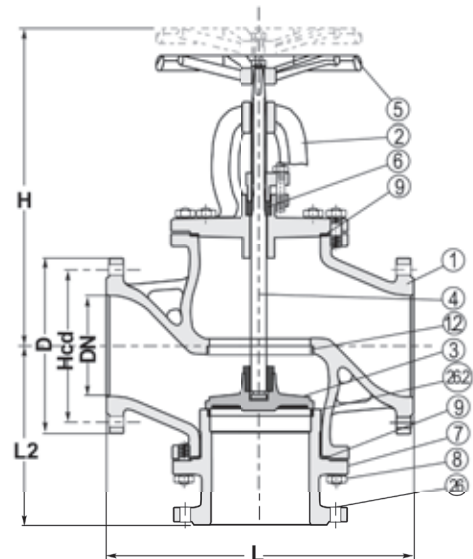

DN 200-250

Variants:

Other dimensions/materials on request

DN	D	Hcd	H	L	L2	Max working-pressure		Weight Kg
						Mpa 120 °C	Mpa 200 °C	
15	95	65x4x14	229	130	65	1,6	1,3	5,6
20	105	75x4x14	229	150	70	1,6	1,3	6,8
25	115	85x4x14	240	160	75	1,6	1,3	7,9
32	140	100x4x18	242	180	80	1,6	1,3	10,9
40	150	110x4x18	283	200	90	1,6	1,3	14,6
50	165	125x4x18	277	230	100	1,6	1,3	18,0
65	185	145x4x18	350	290	120	1,6	1,3	26,2
80	200	160x8x18	371	310	130	1,6	1,3	37,0
100	220	180x8x18	430	350	150	1,6	1,3	54,0
125	250	210x8x18	508	400	200	1,6	1,3	84,2
150	285	240x8x22	578	480	210	1,6	1,3	124,0
200	340	295x12x22	636	600	350	1,6	1,3	155,0
250	405	355x12x26	736	730	440	1,6	1,3	290,0