

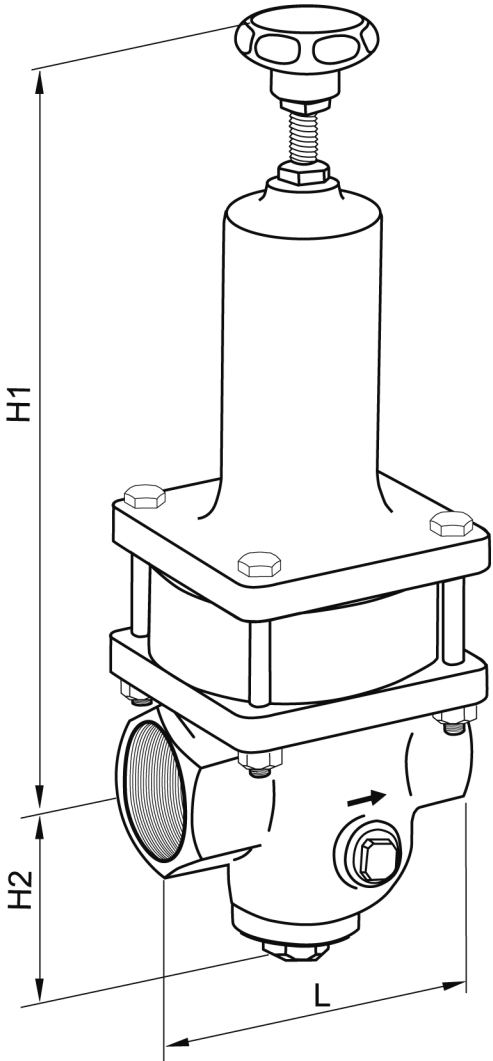

# Pressure-reducing VALVE

|               |
|---------------|
| <b>471023</b> |
| <b>PN 40</b>  |

| No | Part | Material   |
|----|------|------------|
| 1  | Body | Bronze RG5 |
| 2  | Seal | NBR        |
| 3  |      |            |



Pressure reduction for compressed air, nitrogen, and other non combustible gases, water and other neutral non-viscous fluids.

*Not suitable for steam!*

| DN        | H1      | H2 | L   |  |  |  |  | Max Inlet pressure | Weight Kg |
|-----------|---------|----|-----|--|--|--|--|--------------------|-----------|
| <b>8</b>  | 130/143 | 48 | 70  |  |  |  |  | 40 bar             | 0,5       |
| <b>10</b> | 130/143 | 48 | 70  |  |  |  |  | 40 bar             | 0,6       |
| <b>15</b> | 140/157 | 48 | 85  |  |  |  |  | 40 bar             | 1,2       |
| <b>20</b> | 140/157 | 48 | 85  |  |  |  |  | 40 bar             | 1,3       |
| <b>25</b> | 185     | 55 | 95  |  |  |  |  | 40 bar             | 1,6       |
| <b>32</b> | 230     | 61 | 104 |  |  |  |  | 40 bar             | 4,2       |
| <b>40</b> | 230     | 61 | 108 |  |  |  |  | 40 bar             | 4,5       |
| <b>50</b> | 295     | 64 | 147 |  |  |  |  | 40 bar             | 7,2       |