



VENT CHECK VALVE

474961

PN 10

No	Part	Material
1	Body	Hot galvanized
2	Seat	Neoprene
3	Cover	Hot galvanized
4	Float cover	PE
5	Guiding pin	Stainless steel 316
6	Float disc	PE

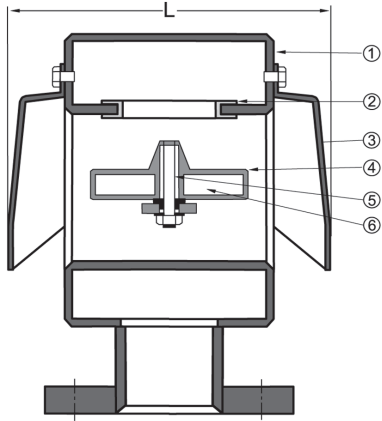
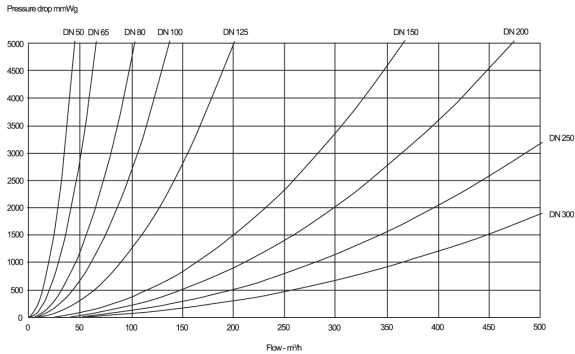
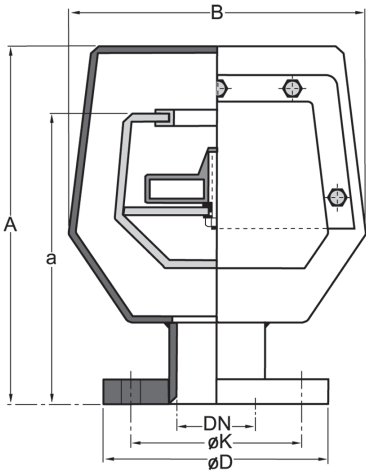

Variants:
 Epoxy coated or stainless steel 316 L execution.
 Flame screen, stainless steel 316

DN	Inch	A	a	B	L	K	D	Holes dia		Weight Kg
								no	dia	
40	1-1/2	263	222	213	223	110	150	4	18	6
50	2"	263	222	213	223	125	165	4	18	15
65	2-1/2	263	222	213	223	145	185	4	18	20
80	3"	310	255	270	257	160	200	8	18	25
100	4"	310	255	270	257	180	220	8	18	30
125	5"	335	280	302	304	210	250	8	18	40
150	6"	448	356	385	366	240	285	8	22	50
175	7"	477	392	430	411	270	315	8	22	60
200	8"	517	425	470	461	295	340	8	22	100
250	10"	660	530	590	536	350	395	12	22	140
300	12"	731	585	685	681	400	445	12	22	200
350	14"	887	700	885	766	460	505	12	22	
400	16"	887	700	885	766	515	565	12	28	