



STRAINER

483697

ANSI 150

No	Part	Material
1	Body	ASTM A351 Gr.CF8M
2	Screen	SUS 304
3	Gasket	Non-Asbestos
4	Cap	ASTM A351 Gr.CF8M
5	Bolt	ASTM A193 B8
6	Drain Plug	ASTM A351 Gr.CF8M

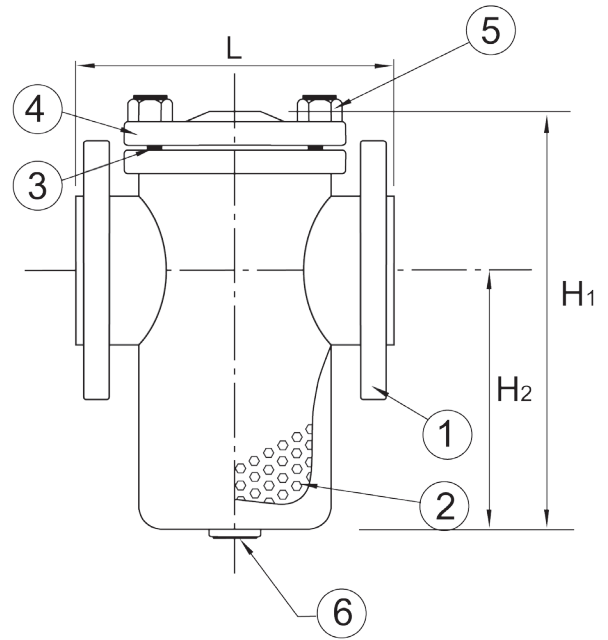

Variants:

Other dimensions/materials on request

DN	inch	L	Hcd	H2	H1	Max working-pressure, Mpa		Weight Kg
						-29 to 38 °C	180 °C	
25	1"	152	79	83	174	1,96	1,58	8
40	1-1/2"	164	98	120	216	1,96	1,58	9,2
50	2"	210	121	128	216	1,96	1,58	11,8
65	2-1/2"	222	140	135	260	1,96	1,58	15,9
80	3"	254	152	173	306	1,96	1,58	20,9
100	4"	290	191	244	390	1,96	1,58	36,3
125	5"	336	216	280	430	1,96	1,58	40,9
150	6"	380	241	244	410	1,96	1,58	60,8
200	8"	467	298	320	560	1,96	1,58	132,6
250	10"	508	362	330	610	1,96	1,58	181,6
300	12"	666	432	420	760	1,96	1,58	313,3